

LOC	QTY	ZONE	LTN	DESCRIPTION	DATE	APPD
G	14		H	REVISED PER 0720-0230-93	2/25/94	AMP

REVISIONS	
NO	DESCRIPTION
1	REVISED PER 0720-0230-93

**METRIOR**  
DIMENSIONS LISTED IN MM [ INCHES ]

<b>AMP</b> WIRE RANGE	<b>UL</b> E13288 Listed
12-10 AWG STRANDED	12-10 AWG STRANDED
<b>LR7189</b> Certified	MILITARY P/N AND CLASS
NOT CERTIFIED	NOT APPLICABLE

△ STAMP AMP 12-10\* APPROX AS SHOWN

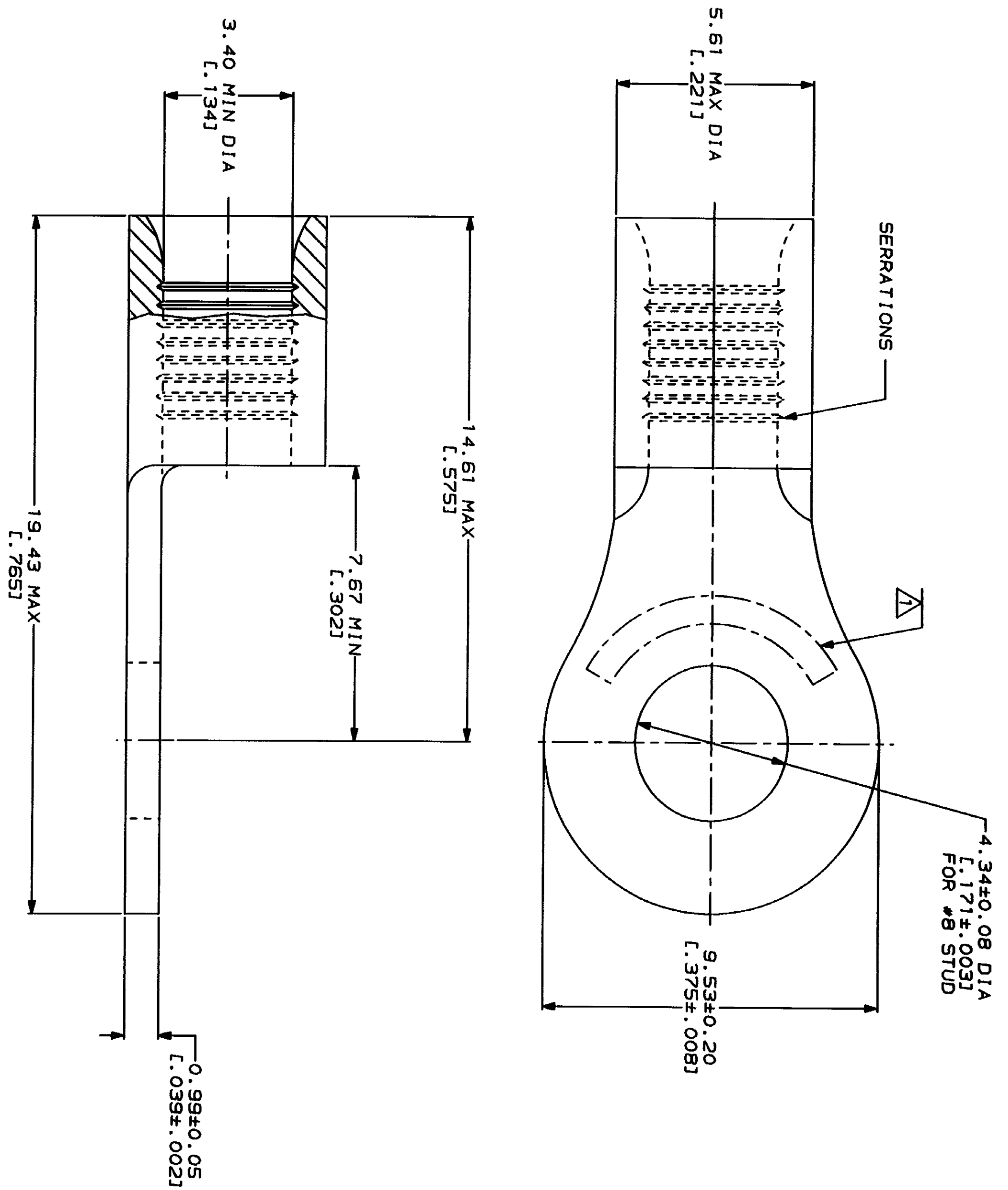

**AMP INCORPORATED**  
**CUSTOMER SERVICE SYSTEMS**

FOR ADDITIONAL PRODUCT INFORMATION OR COPIES OF DRAWINGS AND TECHNICAL DOCUMENTS  
1-800-522-6752

FOR APPLICATION TOOLING INFORMATION  
1-800-722-1111

FOR ORDER ENTRY  
1-800-526-5142

PRODUCT INFORMATION CENTER  
1-800-522-6752

TOOLING ASSISTANCE CENTER  
1-800-722-1111

MAX RECOMMENDED OPERATING TEMPERATURE: 170°C MAX

VOLTAGE RATING: NOT APPLICABLE

WIRE CROSS SECTIONAL AREA RANGE: 2.62-6.64mm<sup>2</sup> [5,180-13,100] CIR MILS STRANDED

DO NOT SCALE PRINT. UNLESS SPECIFIED OTHERWISE DIMENSIONS IN MILLIMETERS. TOLERANCES ON: 1. P/LC DEC ± .1 2. P/LC DEC ± .05 3. P/LC DEC ± .02 ANGLES MATERIAL

FINISH: TIN PLATE  
0.00254 [L. 000100] MIN THK PER MIL-T-10727

DR 2-9-93 TA BRINKMAN	APPD 2-9-93 DE MILLER	NAME
CHK 2-9-93 DA PATTERSON	APPD 2-9-93 JL NECKLEY	TERMINAL, RING TONGUE, BUDGET
APPD 2-9-93 DE MILLER	PRODUCT SPEC	
APPD 2-9-93 JL NECKLEY	APPLICATION SPEC	

<b>AMP</b>	AMP Incorporated Harrisburg, PA 17105-3608
31113	PART NO
00779	CAGE CODE
31113	DRAWING NO
10:1	SCALE
1 OF 1	SHEET